

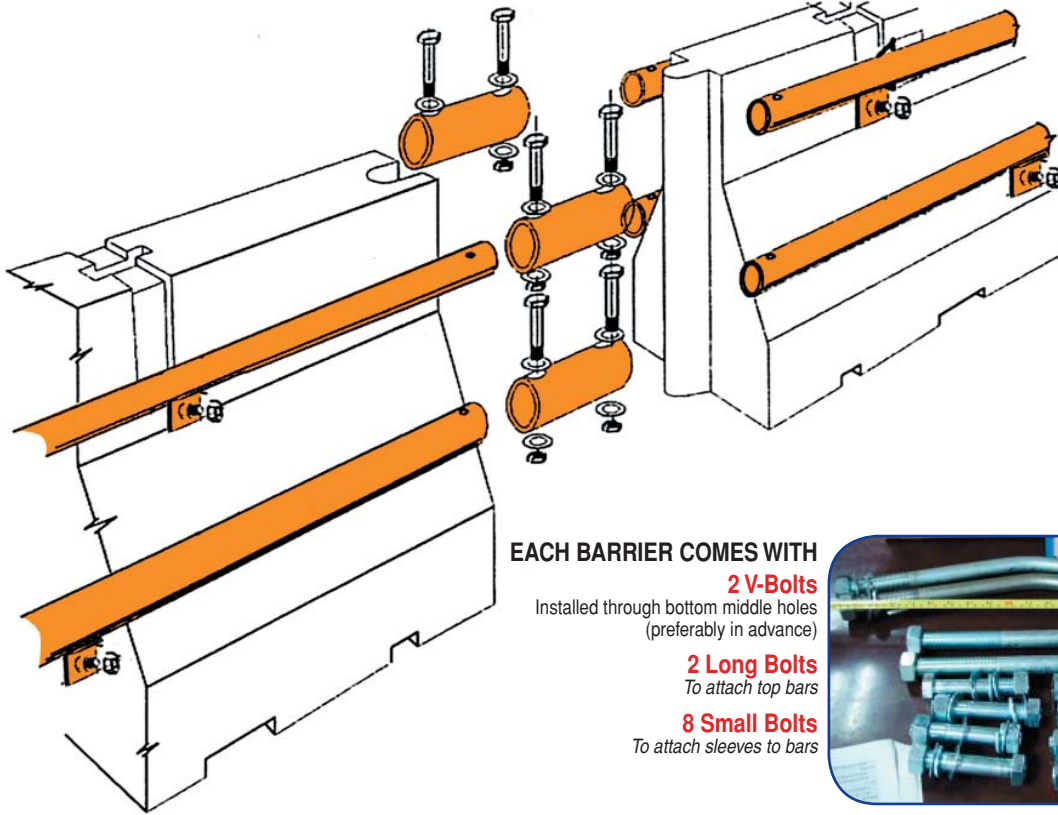

MB350 Barrier Installation Instructions



EACH BARRIER COMES WITH

2 V-Bolts

Installed through bottom middle holes (preferably in advance)

2 Long Bolts

To attach top bars

8 Small Bolts

To attach sleeves to bars



CERTIFICATIONS

- Meets MUTCD specification 6F.65, 6F.68 and 6F.81 as a barrier.
- Meets NCHRP-350 requirements at TL3 as a barrier.
- FHWA approved as a barrier.
- FHWA acceptance letter B34G (see our web site).

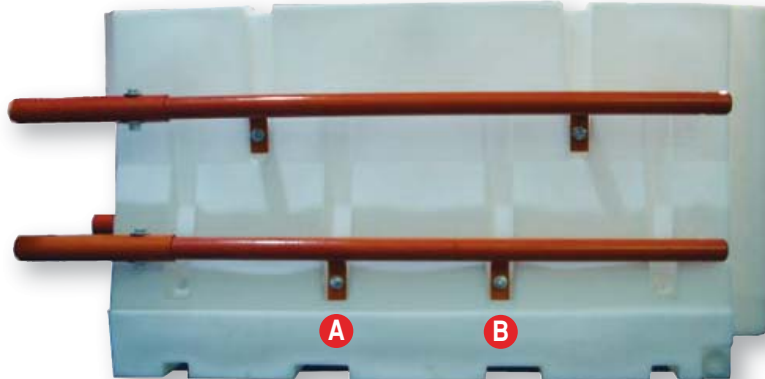

Instructions:

1. If possible, install the two V-bolts in each barrier before barriers are set in their final position. Insert them through the bottom middle holes (indicated by A & B) and attach the nuts. Installing the v-bolts is easiest when the installer can move the barrier around and access it from underneath.
2. Once V-bolts are installed, the next step is to set up the plastic barrier line.
3. Next, attach the bottom rails to the first barrier. Take off the V-bolt nut, attach the lower bar and tighten on the nuts. Attach the top rails to the first barrier using the two long, straight bolts.
4. Then slide the sleeve onto the ends of the top and bottom bars of the first barricade but don't bolt them on.
5. Remove the nuts from the V-bar ends of the 2nd barrier. Slide the end of barrier #2's rails onto the sleeve. Now attach the bottom rail. Repeat for the top bar.
6. Finally, bolt the sleeve to the bars using the small bolts.